



VPM1 - 04

DIRECTLY OPERATED PRESSURE RELIEF VALVES

| KE 3050 | 08/14 |

D_n 04 | p_{max} 35 MPa | Q_n 6 dm³/min



Directly operated pressure relief valves are used in circuits where the pressure must not exceed adjusted value or in circuits requiring a safety valve.

Dn 04, NG 04 | Subplate mounting | 4 pressure ranges | special design for hydraulic circuits with 2/2 way cartridge valves | designed for vertical stacking assemblies

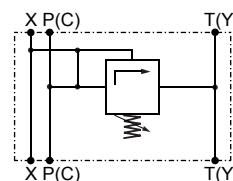

FUNCTIONAL DESCRIPTION

Direct operated pressure relief valves VPM1-04 comprises of the valve housing **1**, poppet **2** and seat **3**, return spring **4**, poppet guide **5** and adjusting screw **6**. Port P and port X of the valve are connected internally. Return spring **4** pushes the poppet **2** to the seat **3** and holds the valve closed. Once the force caused by the pressure in port X acting on the exposed surface area of the poppet **2** exceeds the spring force, the poppet **2** moves towards the spring **4** and enables the flow to pass from port P to tank (T). The force of the spring acting on the poppet determines maximum pressure in the circuit (in ports P and X) and can be set by adjusting screw. To optimize the valve performance, four pressure ranges are available. Choosing the closest range is recommended. Valve housing **1** is phosphate coated.

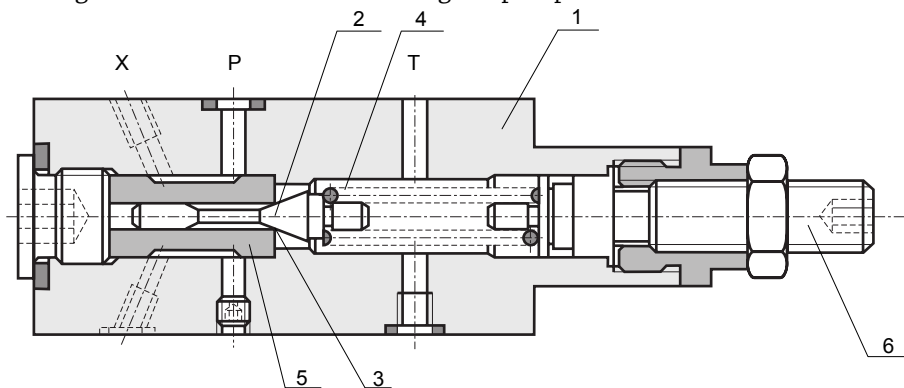

ORDERING CODE

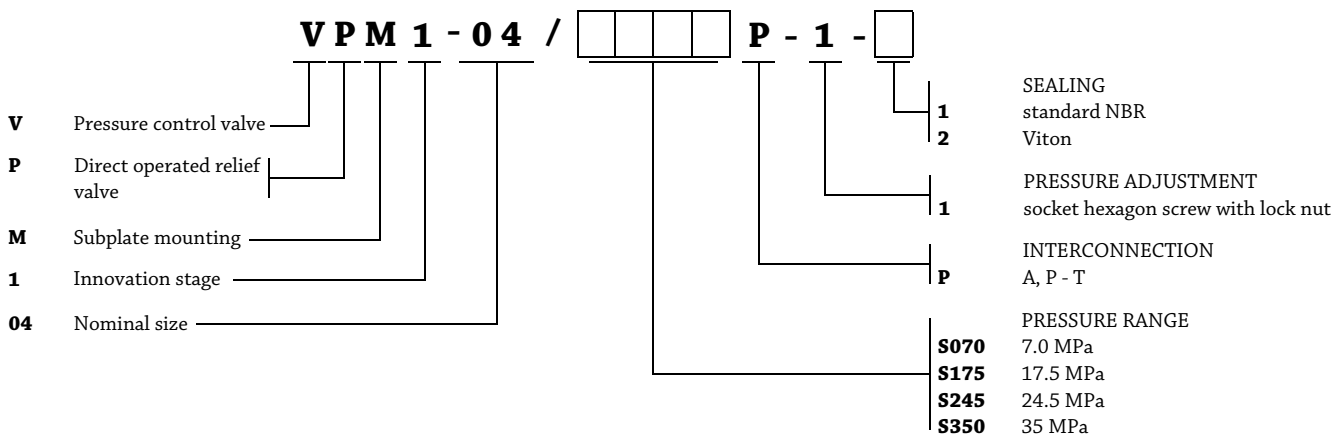

Note: Direct operated pressure relief valves VPM1-04 are a new version of well established DBDP - 04 / S XXX P - 1 - X with improved valve components and performance.



INSTALLATION, SERVICE AND MAINTENANCE

Directly operated pressure relief valves VPM1-04 are designed for in-line mounting in vertical stacking assemblies. The reliability of the valves is conditional upon use of prescribed working fluid, especially its parameters such as cleanness and temperature. It is required that the contact surfaces of the valve must be clear and intact before installation. O-rings must not be disshaped or damaged by any means. Flatness deviation and roughness of the subplate shall not exceed 0,01/100 mm and Ra = 1,6 μm respectively. Relief valves VPM1-04 can be installed in any position and do not require any special maintenance.

DELIVERY

Directly operated relief valves VPM1-04 are delivered assembled including sealing rings. Spare parts and mounting screws are not included in the package. These must be ordered separately.

TECHNICAL DATA

Technical data	Symbol	Unit	Value
Nominal size	Dn	mm	6
Installation dimensions	see chapter Installation dimmensions		
Flow direction			A, P → T
Pressure range		Mpa	0 - 35
Individual pressure ranges	P _{MAX}	MPa	7 17.5 24.5 35
Nominal flow	Q _n	dm ³ /min	6
Working fluid	Hydraulic oils of power classes (HL, HLP) according to DIN 51524		
Fluid temperature range NBR (Viton)	t _{PO}	°C	-30...+80 (-20...+80)
Max. ambient temperature	t _A	°C	-20...+60
Working fluid viscosity range	ν	mm ² /s	4 ... 400
Maximum degree of fluid contamination	Class 21/18/15 according to ISO 4406 (1999)		
Lowest adjustable pressure	P _{MIN}	MPa	see characteristics
Mounting position			optional

INSTALLATION DIMENSIONS

Note: All dimensions in mm

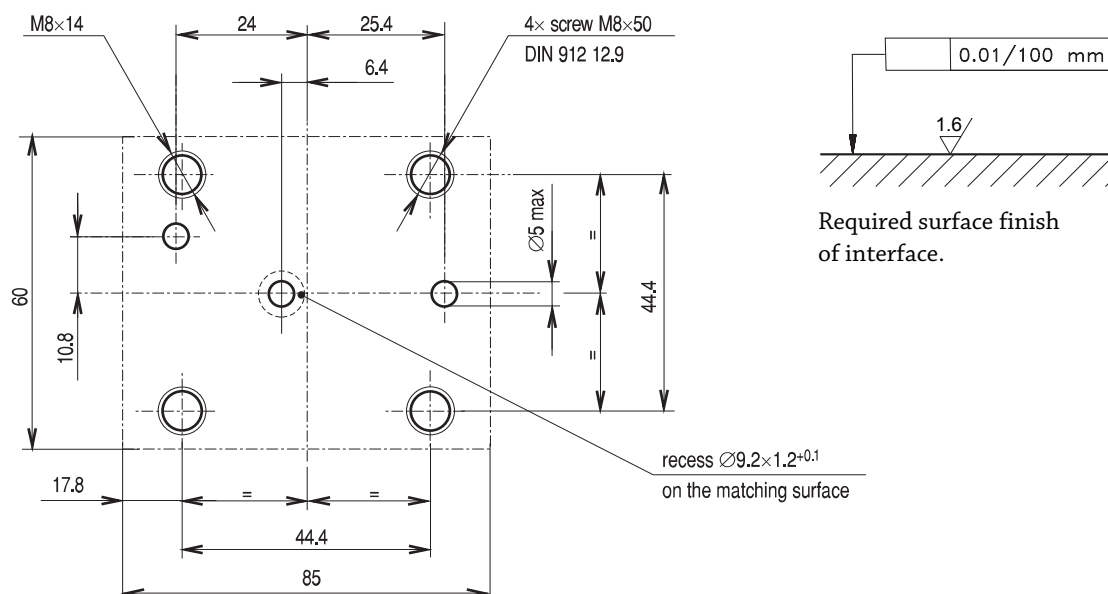

Note: Pressure relief valves VPM1-04 are designed to be used in special hydraulic circuits. **See Application**

PRESSURE-FLOW DIAGRAM

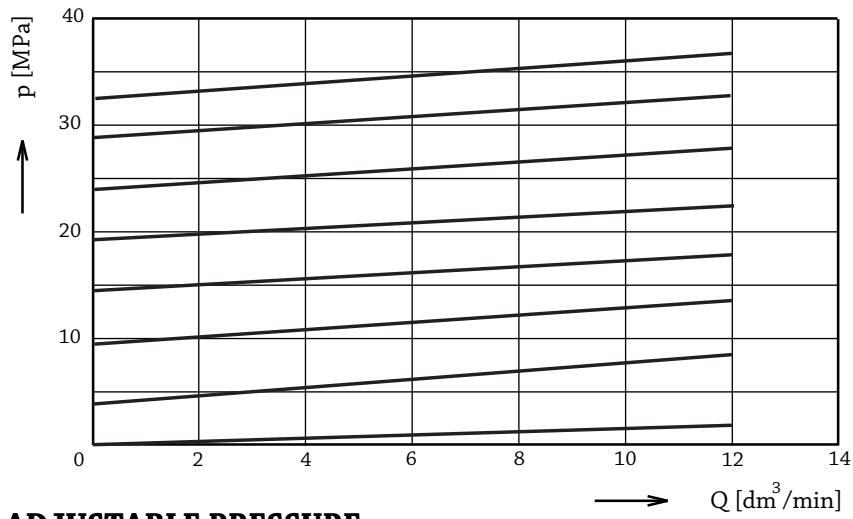

THE LOWEST ADJUSTABLE PRESSURE

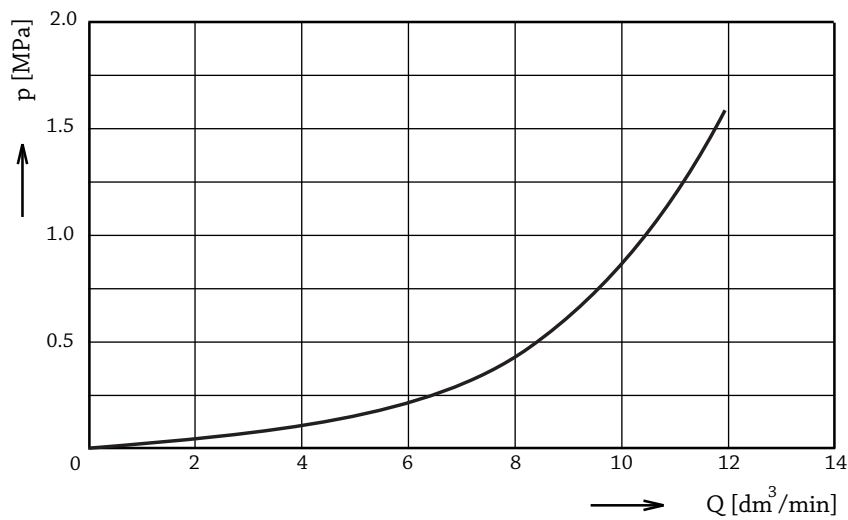

PRESSURE DIAGRAM OPENED-CLOSED

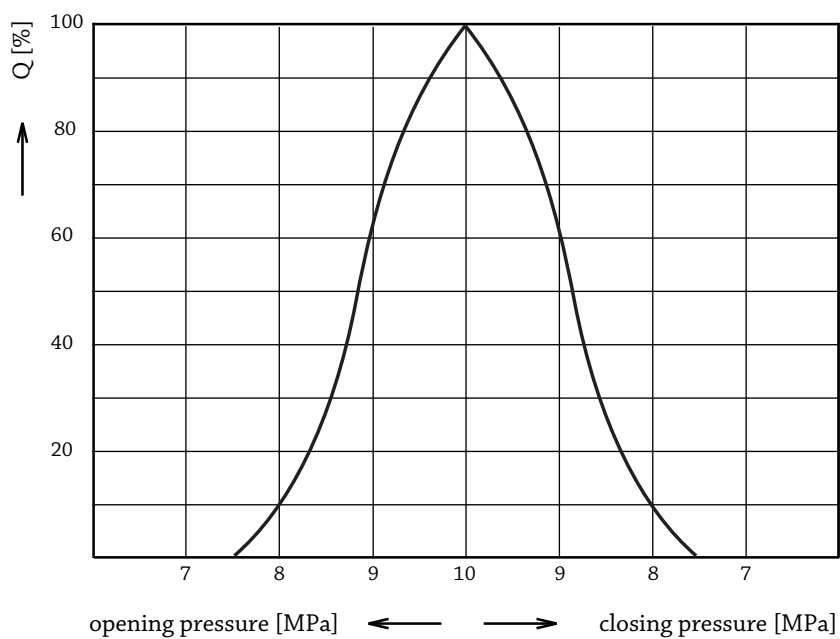

VALVE DIMENSIONS

Valve housing width = 60 mm

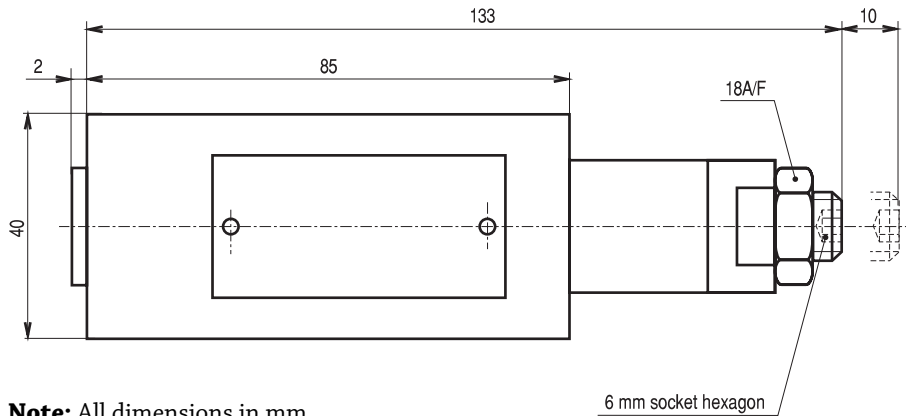

Note: All dimensions in mm

APPLICATION

Installation dimensions of the relief valves VPM1-04 are designed for vertical stacking assemblies in hydraulic circuits e.g. circuits involving cartridge valve. Single and double relief valves with standard installation dimensions according to DIN 24 340 / ISO 4401 / CETOP are available as VP(2)M1-06 (Dn 06) and VP(2)M1-10 (Dn 10).

Cartridge manifold installation dimensions

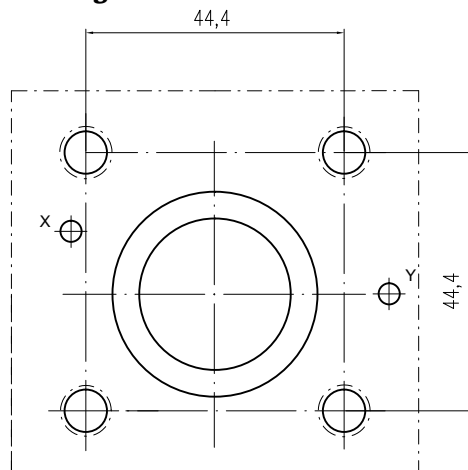

NOTES

Example of circuit with cartridge valve

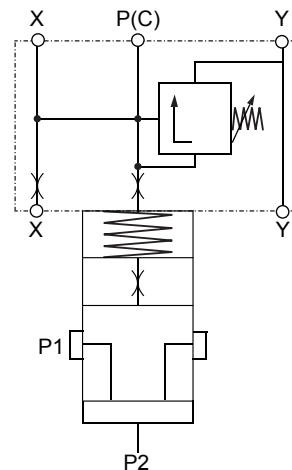

Consultancy service is provided by: **PQS Technology, Ltd.**

Sales department: tel.: +420 313 526 236

Technical support: tel.: +420 313 526 378

Fax: +420 313 513 091

www.pqstechnology.co.uk

e-mail: export@pqstechnology.co.uk

e-mail: info@pqstechnology.co.uk